



# History of the Silent Giant

By Jim Lemke



## OVERVIEW

When introduced in the late 1950s, the SILENT GIANT was a unique and quiet aquarium air pump for its time, only producing a slight hum. Other vibrator type pumps were not as quiet and noisier. It produced more air than other vibrator type pumps, so much that it could “run up to 12 box filters” according to advertising information. It also produced pressure in the 4-6lb range, whereas vibrator pumps put out about 2-3lbs pressure. It was considered the pump to own from the 1960s through much of the 1980s.

## INTRODUCTION

First of all, I have no direct knowledge of the history of this iconic aquarium air pump. My knowledge comes from operating a tropical fish shop starting in 1961, not many years after the SILENT GIANT was first introduced. The shop continued until 2016, far past the demise of the Silent Giant in the late 1980s.

How I got started in opening the shop at the age of 15 is for another time. For a brief glimpse of my interest in fish, it started when I was 13 or 14. I got hooked on fish and soon ended moving my tanks into the basement. I never had a SILENT GIANT when I was a kid, but I remember having a blue noisy WIL-NESS vibrator pump and then a noisy Danner SUPREME SPECIAL piston pump. It should be noted that most of the air pumps were made in the US, except for the STAR pump, which was made in France. Soon, with the help of my dad, we moved the tanks into the basement, giving room to expand. We built a compressor to run them all.



Star Air Pump (made in France)

It should be mentioned that most tanks at that time were stainless steel and were filtered with box filters, or hang-on-the-tank air-operated outside filters. Electric power filters may have been available for large tanks at that time, but air pumps were the way to maintain a tank.

More tanks were added, and fish were bred and sold to local pet shops. As a family, we decided to start a fish shop in the basement of our home. We contacted Carl Naja, a wholesaler in Milwaukee, for fish and supplies. He suggested that I should carry the SILENT GIANT air pump as it would appeal to aquarists who had more than one tank and wanted a quiet pump. So that's how I learned about the Silent Giant.

### THE BEGINNING

From my research, a man by the name of R.R. Hull came up with a unique way to make air for aquariums in the late 1950s. I can only surmise that he was a hobbyist and was frustrated with what was available. He must have had a mechanical mind because what he came up with was a pump mechanism unlike any other pump available then or up to this very day! It was so unique that he was awarded a US patent, No. 2,961,149 on Nov. 22, 1960. Interesting that the patent was filed on May 14, 1957 (Copy attached).

This unique pump design was called an oscillatory compressor, basically a very short piston driven by an electromagnet instead of an electric motor, and only used 4 watts. The stroke was so short that the seal, which connects the moving sleeve to the stationary piston, is not subjected to sliding wear. This inner mechanism was surrounded by gravel, a totally unique idea! It should be noted that the gravel type stayed the same for all years of production.

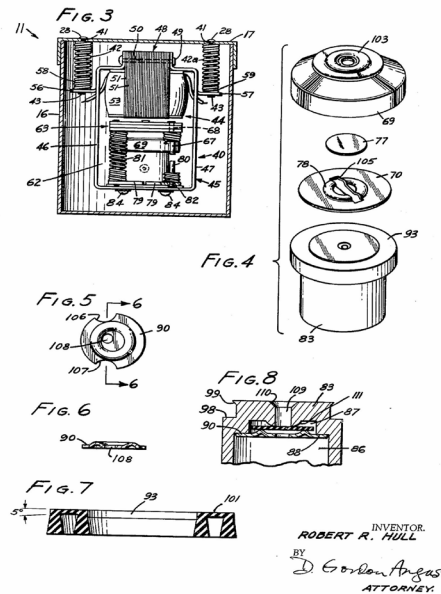
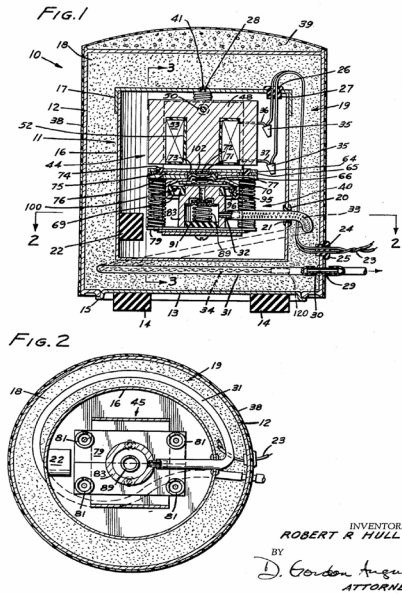

The patent was for the original quart-size, tin can or "cigar can" design. Apparently, cigars came in similar cans in the 1950s.

I noticed several differences in the illustrations of the patent from any "cigar can" pumps I've ever seen:

1. The patent calls for a domed lid filled with plaster to aid in sound deadening.
2. In the patent illustration, there is no mention of a felt in the inner can.
3. The patent does not show an internal felt on the bottom of the outer can.
4. The patent does not show a removable outer prefilter that came with production pumps (Figs. 1 and 2).



Figure 1 Version One Prefilter

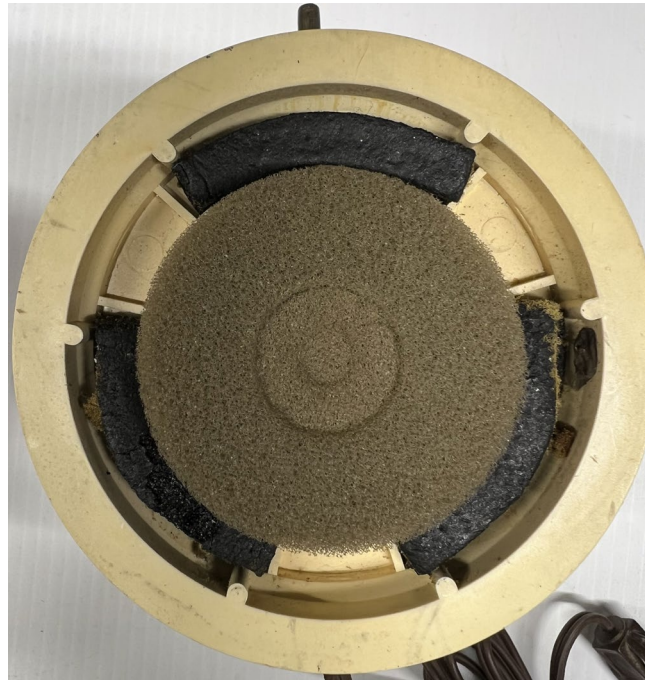

Figure 2 Version Two and Three Prefilter

It was sometime in the early 1960s that this early model was replaced with the iconic plastic case. I'm not sure if the design of this new plastic case was ever copyrighted or patented.

### THE THREE VERSIONS

Perhaps this is a good time to mention the three versions of the pump. The dates mentioned below are my estimates:

1. Original Version One: 1957 to 1961. Known as the metal tin can or "cigar can" version.
2. Second Version: 1962 to 1969. Known as the plastic case "Vertical Label" version.
3. Third Version: 1970 to 1988 (?). Known as the plastic case "Colorful Square" version.

The following are some differences imprinted on the bottom base of the different versions (Figs. 3-5):

1. All three versions had an "R" after the Silent Giant's name. The "R" means that the name was submitted to the United States Patent and Trademark Office and given authority to exclusively use the Silent Giant name. I believe a fee was required to keep the registration active.
2. Versions two and three used the phrase "AIR TO SPARE". Version one and early version two pumps did not have an "R," but later version one pumps did, as well as all version three pumps
3. Versions one and two had the patent number printed on the base. Version three had "Patent Pending". I'm not sure if all of the early version three pumps had this. Apparently, the company didn't pay the fees to keep the patent in effect.
4. On July 1, 1963, the United States Postal Service began requiring zip codes to be added to addresses on correspondence and mailings. It was not a legal requirement to have the zip code placed on the product. But at some point in the late 1960s, the zip code was added on the base of version two pumps.
5. The first version did not have a reference to "UL" or "SA". These are agencies that test products for safety and not how well a product works. I note that the "UL" symbol is on all the two and three versions. The "SA" was missing from version three. There was also a City of Los Angeles sticker (Fig. 6) that was on versions one and two (not sure about version three). This sticker showed that the pump met the requirements of the electrical code for the City of Los Angeles.
6. All three versions have the date of manufacture stamped on the base, many times unreadable. Versions two and three also had a sticker on the side with a serial number.



Figure 3 Base of Version One

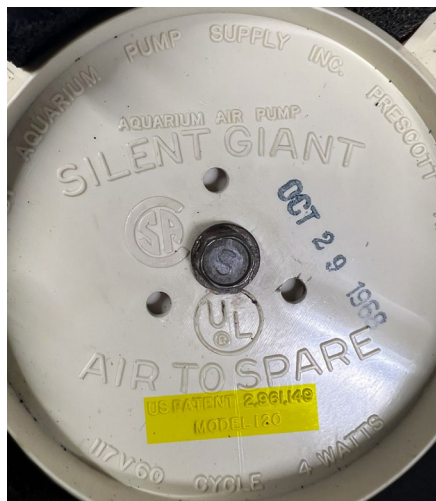

Figure 4 Base of Version Two



Figure 5 Base of Version Three



**Figure 6** City of Los Angeles Sticker

Remarkably, there were very few differences in the working mechanism between the three versions. It should be noted that none of these differences improved the noise or air output level. These changes must have been for cost savings and to make assembly more efficient. The following are some of these changes I noticed:

1. Version One pumps had the electrical cord and the air output coming out of the front of the pump. The other versions had the electrical cord exiting from the back.
2. Early Version One pumps and early Version Two pumps used a “C” wire clip to hold the rubber “U” cup in place (Fig. 7).
3. As in 2 above, the pumps used a spring to hold the muffler tube onto the piston nozzle (Fig. 7).
4. At some point in the early Version Two pumps, the piston was changed from zinc to aluminum. This didn't last long, and the pistons were changed back to zinc (Fig. 8).
5. In the early 1960s, a polarized plug was added to Version Two pumps as the US electrical code was changed for safety.
6. All three versions had a round piece of felt used as an inner air filter. Version One pumps had the felt sandwiched between the inside on the steel base and a steel cover soldered to the base (Fig. 9). Version Two and Three had the felt between the screwed on inner base and the screwed on outer base (Fig. 10).

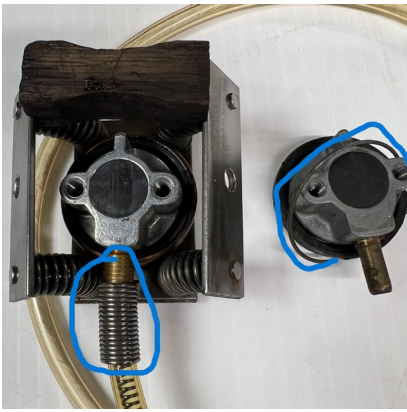

**Figure 7** Version Two Spring and “C” Clip

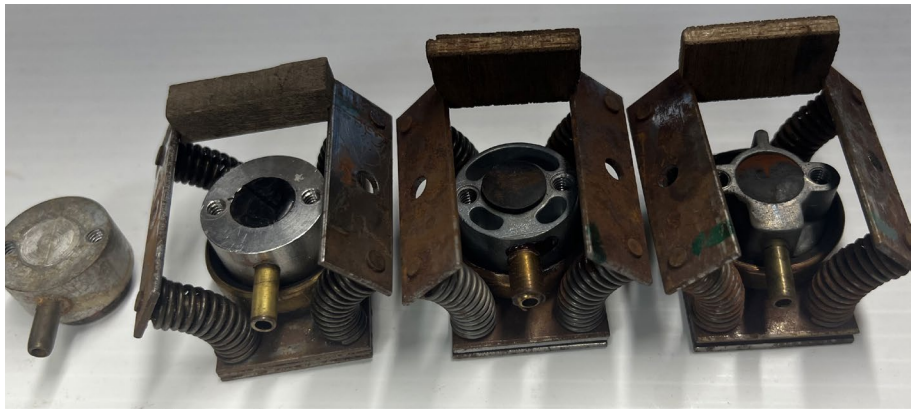

**Figure 8** From left to right: Aluminum Piston with Aluminum Plug, Aluminum Piston, Early Version of Two Zinc Piston, Later Zinc Piston



**Figure 9** Version One Felt



**Figure 10** Version Two and Three Felt

## BACK TO HISTORY

When I first started my shop in 1961, I never knew the first version existed. Since I’m not familiar with the company’s origins, I do know that it was named Aquarium Pump Supply and was located at 314 Whipple Street, Prescott, Arizona. However, only the city and state appeared on the “cigar can” pump. I assume they started selling them locally and probably through a local distributor, and expanded distribution later to all over the US. I’m not sure how many pumps a distributor had to buy or if there were different levels of the quantities they had to buy. A retailer couldn’t buy the pumps directly but only through a distributor. I’m not sure what the “cigar can” pumps sold for or how it was packaged. When I started selling them, it was the plastic case version two. The boxes were stamped with “FAIR TRADE” and a price of \$14.95. What Fair Trade meant was that the manufacturer set the price it would sell for, apparently across the entire US. Thus, the consumer would know that the price would be the same wherever it was purchased. This was to change in a few years as FAIR TRADE became a legal issue.

**RELIABLE — ECONOMICAL — QUIET — SAFE**

Made of the finest materials . . . Built to last for years and years . . .  
Nothing to oil . . . Nothing to adjust . . . Nothing to wear . . .

A sturdy compressor that pumps with ease into the deepest tanks . . .  
An air output so enormous that it is suitable for any aquarium use . . .

Operating cost less than one tenth that of ordinary motor powered  
pumps . . . Thoroughly insulated and encased to eliminate fire and  
shock hazards . . .

No uncontrolled vibrator to rattle, clatter, and knock as it ages . . .

No exposed moving parts to hurt children and pets . . . or anyone else . . .

Perfect for use with a single small tank or with several large ones . . .

Perfect to use or to give . . . Perfect for everyone . . .

**BACKED BY A TWO YEAR WRITTEN GUARANTEE . . .**

**BUT FAR MORE IMPORTANT, BACKED BY A FACTORY THAT YEAR  
AFTER YEAR HAS RENEWED — WITHOUT CHARGE — ITS GUAR-  
ANTEE ON EVERY PUMP THAT IT HAS EVER MADE — REGARD-  
LESS OF THE PUMPS AGE OR AMOUNT OF USE!**

Yes, with all these features and many more, silently, inexpensively, and  
faithfully the **SILENT GIANT** blows an abundance of clean, pure, oil-  
free air into the aquariums of an ever increasing number of happy  
owners . . .

**Yours to own and enjoy for a reasonable . . . \$14.95**

SEE IT . . . COMPARE IT . . . BUY IT . . . NOW!  
AT YOUR FAVORITE PET SUPPLY DEALER . . .

*Jim's Aquariums*  
7717-29th AVENUE  
KENOSHA, WIS.  
7 EN 12

# SILENT GIANT®

AQUARIUM AIR PUMP

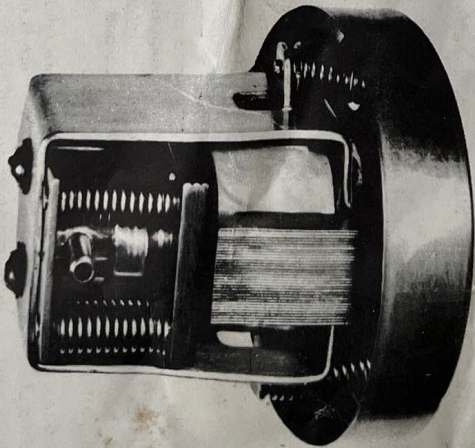

U.S. Patent No. 2,961,149

**BUILT FOR YEARS OF TROUBLE FREE OPERATION  
THE HEART OF THE SILENT GIANT AQUARIUM AIR  
PUMP IS THIS REMARKABLE PUMPING MECHANISM.**

**AIR TO SPARE**

Figure 11A Brochure Front Page - Version Two and Three

**THE SILENT GIANT  
IS A BASICALLY DIFFERENT TYPE OF AQUARIUM AIR PUMP . . . .  
THE SILENT GIANT  
IS ALSO A BASICALLY BETTER AND MORE RELIABLE AIR PUMP . . . .**

These are not mere advertising statements. These are facts, and they are very important facts to everyone interested in aquarium air pumps.

What makes these statements facts? Why is the **SILENT GIANT** basically different? Why is the **SILENT GIANT** better and more reliable?

The United States Government Patent Office, thorough and well informed, after its usual careful examination has allowed claims on twenty-seven constructions used in **SILENT GIANT** design.

Yes, an almost unbelievable twenty-seven (27) new, different and patentable constructions used in the design of one product. No wonder with so many new and improved construction features the **SILENT GIANT** does the things it does. Here truly is no mere rearrangement of the same old trouble-making components used by other pumps . . . .

Unpatented, but just as important to the long life and proper working of the **SILENT GIANT** are many other things such as the special "rubber" formulations for valves and flexible web — formulations developed especially for use in the **SILENT GIANT** . . . . and long lasting, since no such parts have ever needed to be replaced . . . .

The **SILENT GIANT** is different and better and more reliable because the background of its development is different. Here is no frantically put together product, hurriedly marketed without proper testing . . . .

Here, instead, is a pump which was held to such rigorous requirements of performance and quality that more than three years were required for its perfection . . . .

Here is the **SILENT GIANT**, truly a product of real research, patiently conducted without limit as to money or time, a work of love instead of money, a search for quality and performance instead of low price, a search for a fine pump instead of a fine profit . . . .

Today, after more than 8 years of commercial production and use . . . . And with no owner having needed to spend a single cent for repairs . . . . The **SILENT GIANT** stands unchallenged . . . .

**A REALLY GOOD PUMP — AT A REASONABLE PRICE**

Outgrowth of a determination to find answers to the problems which had for so long prevented construction of better air pumps . . . .

Using no more electricity than an electric clock, the **SILENT GIANT** pumps more air than the old-fashioned, power-wasting mechanisms which it obsolesces . . . .

Using a trouble-free cup and plunger compression chamber sealed by an ingenious flexible web, the **SILENT GIANT** eliminates entirely the diaphragms, bellows, and piston seals which have for many years been the major cause of air pump trouble and annoyance . . . .

Using an armature which is accurately controlled and positioned in relation to an electromagnet, the **SILENT GIANT** eliminates the power-wasting electric motors and noisy vibrators found in old-style pumps . . . .

Using a unique method of dynamic balancing, the **SILENT GIANT** pumping mechanism puts to useful work the energy which is usually wasted in shaking the pump and rattling the furniture . . . .

Using a simple but very efficient method of back-pressure compensation, the **SILENT GIANT** pumps the same enormous amount of air with the same remarkable economy regardless of the conditions of air use or the depth of water in the tank — something which is a decided improvement over the past approach of simply ignoring the problem or else merely providing an external adjustment to exasperate the user . . . .

**TRULY A SUPERB PUMP !**

**SOLD BY THE BETTER DEALERS . . . .**

**BACKED BY A MANUFACTURER WHOSE INTENT**

**IS TO HAVE EVERY USER HAPPY . . . .**

**TODAY . . . . TOMORROW . . . . AND IN THE FUTURE . . . .**

**AQUARIUM PUMP SUPPLY, Inc.**  
Prescott, Arizona

Figure 11B Brochure - Back Page Version Two and Three



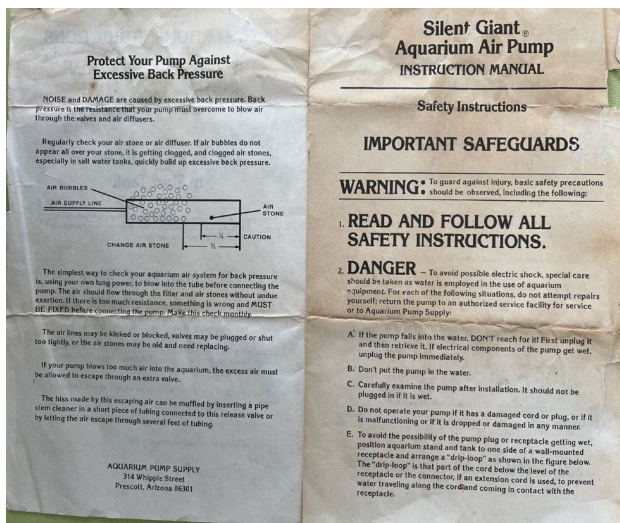

Figure 11C Instruction Manual - front page

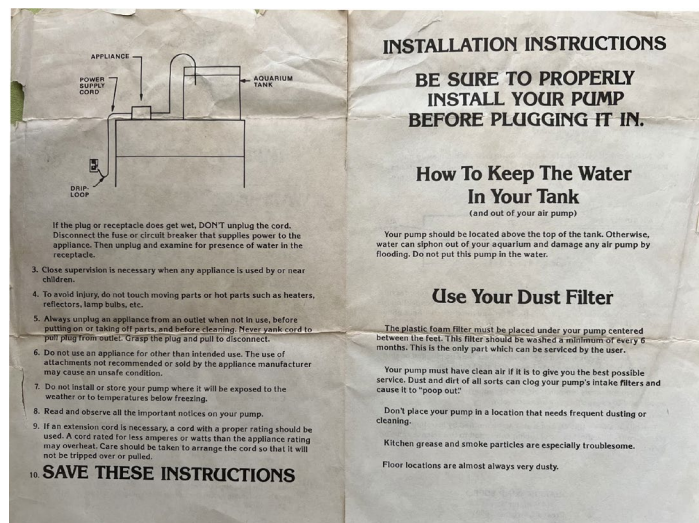

Figure 11D Instruction Manual - back page

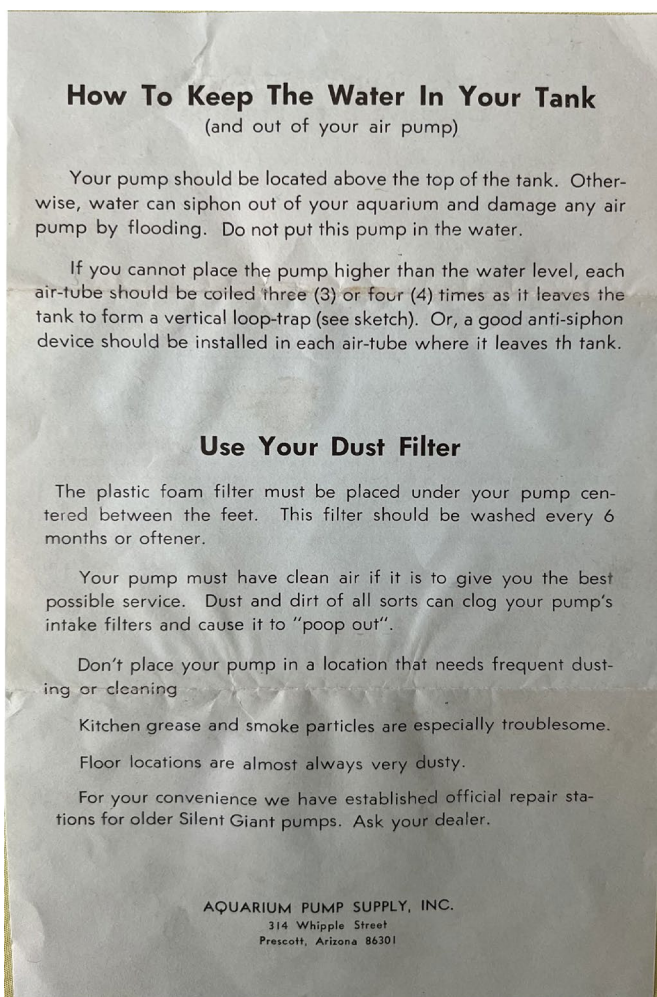
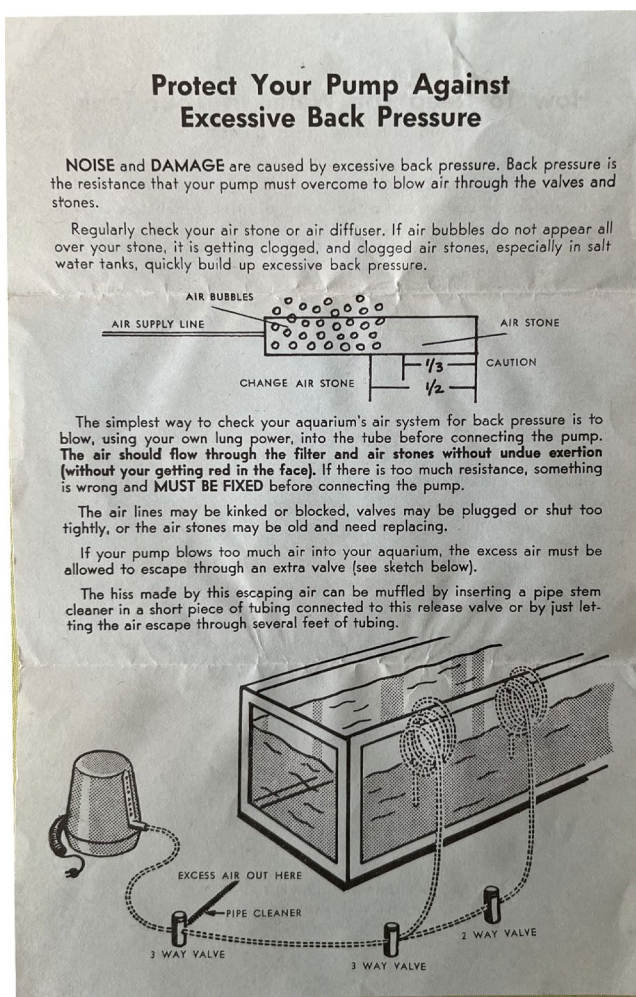

Figure 12 Information sheet



Another interesting marketing plan unique to the pump, was that they had a “LIMITED LIFETIME WARRANTY” (Fig. 13). Once again, I’m not sure about the version one pumps, but what I have knowledge of is starting in the early 1960s, the version two pumps had a full two year warranty with a life time of repairs. After two years, you could still send it in for repair “for any such defect or replace your Silent Giant for its then-current service charge”. Aquarists tended to think of the pump as having a lifetime guarantee and missed the small print. This also wouldn’t last. Also, this policy is why I, as well as other retailers, got into repairing the pumps. At some point, the company came out with repair kits (Fig. 15) that retailers could sell to customers who wanted to repair their own pumps. More on this later.

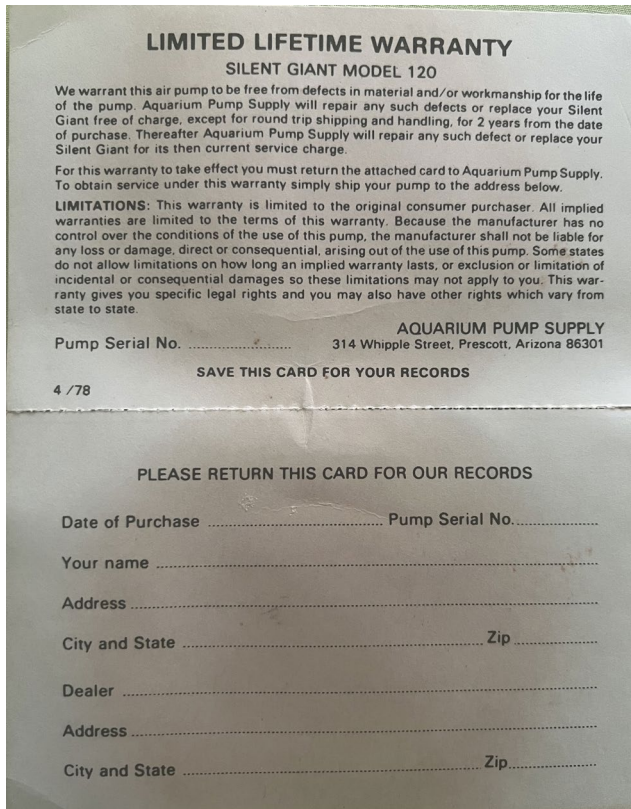

Figure 13 Version Two Warranty Card

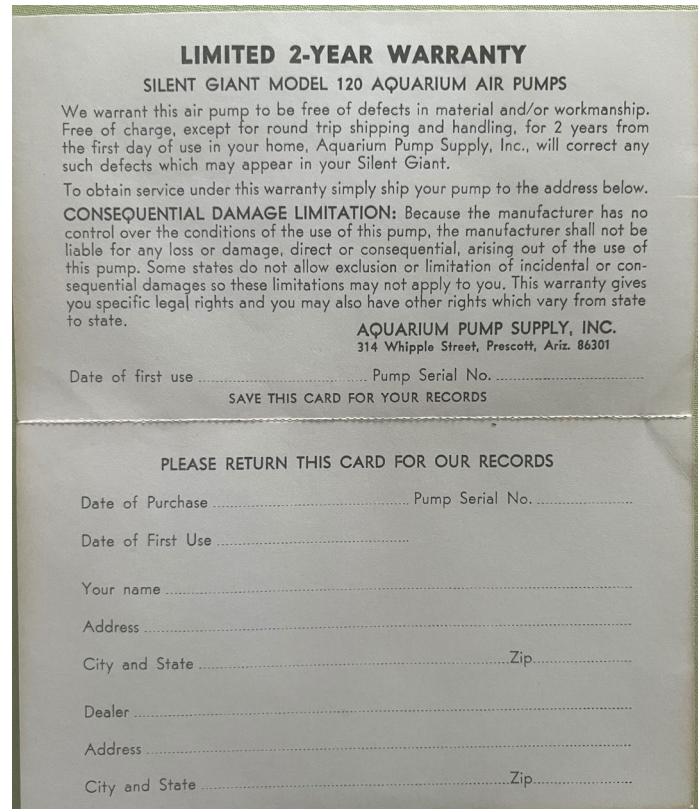

Figure 14 Later Version Two Warranty Card

As time went by, the Silent Giant was still a good seller, but there was more competition and more pumps were coming on the market, many of them imported. Also, there were other ways to filter a tank that became available. Little by little, aquarists began to run their tanks with power filters and power heads. Air pumps were mainly used for effect, such as an air stone or an air-operated toy, like a Penn-Plax burping clam, or a monster!

**CHANGES TAKING PLACE**

At some point, probably in the late 1970s, the Silent Giant pump was given a cosmetic makeover with a new colorful square label and a new, larger colorful box. The pump itself was not changed. This may have been the time when the “ Limited Lifetime Warranty” was changed to a “Limited 2-Year Warranty” (Fig. 14). Nothing was mentioned about repairs after the 2 years. There were several versions of the 2-year warranty cards. The final one changed “warranty” to “guarantee” (Fig. 15). The latest card also stated that the card should be mailed within ten days of purchase to enact the guarantee (Fig. 17).

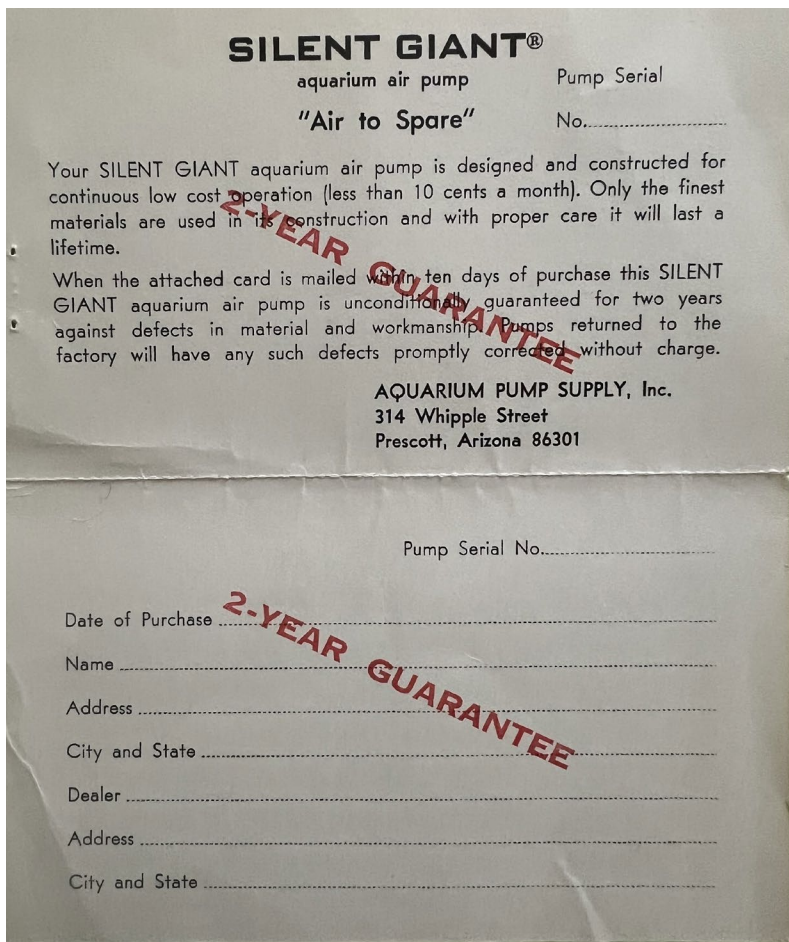

Figure 15 Version Three Guarantee Card

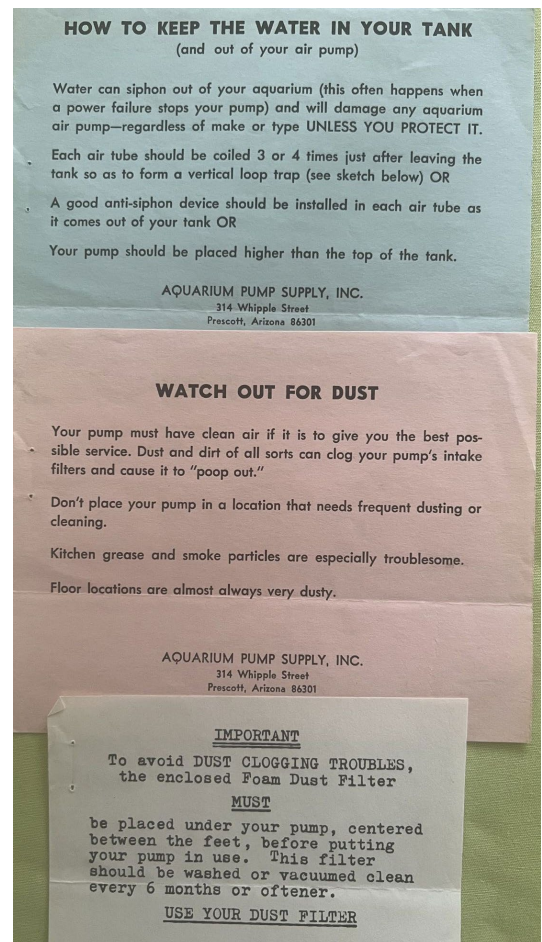

Figure 16 Version Three Reminders

In the early 1980s, the US patent ended on the pump. It doesn't appear that the company tried to maintain the patent, since, on the base of later pumps, "patented" was changed to "patent pending" (Fig. 3). I do remember several companies marketing a pump of similar looks. I acquired one of those years ago and dismantled it to find out the mechanism was in no way similar, but a simple vibrator pump. There was also a "baby" looking pump, and that was also just a vibrator pump. They were both made overseas.

As time went on, probably in the mid-1980s, the brass output nozzle on the front of the pump was replaced with a clear plastic nozzle. A cost savings, I'm sure. But, there were problems in shipping with the plastic nozzles breaking off. It wasn't long before the pumps were changed back to the brass nozzles.

The plastic nozzle debacle was probably a sign that there was trouble brewing, in my opinion. The next big thing is that production was moved to Mexico. This didn't go over very well as the quality control went down, resulting in many returns. I'm not sure if production in Prescott continued at the same time. I don't think the manufacturing in Mexico lasted more than a few years. I'm not sure if production returned to Prescott until the company ceased production in the late 1980s.

The company had never offered any other pump or product other than the repair kit. At some time, probably in the early 1980s, they offered an inside air-operated filter. It was fairly large and seemed cumbersome and didn't blend in with the tank decor. If I had to guess, I think the company lost money on it. Production didn't last long.

## IMPORTANT INFORMATION

(SAVE FOR REFERENCE)

Any aquarium air pump—regardless of make or type—when shut off is likely to be damaged by water siphoning out of the aquarium UNLESS . . . 1) The pump is placed higher than the top of the tank. 2) Good anti-siphon devices are properly installed in each air line that comes out of a tank. 3) Each air tube is coiled three or four times just after leaving the tank so as to form a vertical trap loop.

Do not restrict the air flow from any aquarium air pump by pinching the tubing or shutting the air valves which control the air to your aquarium accessories. If your pump blows too much air into your aquarium, the excess air should be discharged through a valve. Any noise made by this escaping air can be muffled by inserting a pipe-stem cleaner into a short piece of tubing connected to this valve.

Do not shut off your aquarium pump at night because, in the dark, aquarium plants use oxygen instead of liberating it.

## IMPORTANT INFORMATION

(SAVE FOR REFERENCE)

Any aquarium air pump—regardless of make or type—when shut off is likely to be damaged by water siphoning out of the aquarium UNLESS . . . 1) The pump is placed higher than the top of the tank. 2) Good anti-siphon devices are properly installed in each air line that comes out of a tank. 3) Each air tube is coiled three or four times just after leaving the tank so as to form a vertical trap loop.

Do not restrict the air flow from any aquarium air pump by pinching the tubing or shutting the air valves which control the air to your aquarium accessories. If your pump blows too much air into your aquarium, the excess air should be discharged through a valve. Any noise made by this escaping air can be muffled by inserting a pipe-stem cleaner into a short piece of tubing connected to this valve.

Do not shut off your aquarium pump at night because, in the dark, aquarium plants use oxygen instead of liberating it.

AQUA  
314 V  
Presco

Place  
Stamp  
Here

AQUARIUM PUMP SUPPLY, Inc.  
314 Whipple Street  
Prescott, Arizona 86301

Figure 17 Mailing side of warranty/guarantee card

## A CHANGE IN DISTRIBUTION

First, a brief view of how distribution worked for independent fish shops in the 60s through the 80s. Retailers bought their supplies from distributors. Some distributors also sold freshwater tropical fish, as saltwater fish were a rarity. Different distributors might carry different products, so the retailer might have several distributors. The distributors would have to buy a certain number of the products as required by the manufacturer. The retailer usually could buy just what was needed from the distributor.

Carl Naja was my main distributor. I drove up to Milwaukee almost every week to get supplies to keep up my inventory. As for the Silent Giant pump, I would buy the number of pumps I sold the last week to keep my inventory up. Now, back to the Silent Giant's history.

In the late 1980s, the company decided to eliminate the distribution of the Silent Giant through distributors. This was something new for the time! As a retailer, if I wanted to continue to sell the pump, I'd have to buy the pumps directly from the Aquarium Pump Supply Co. at a minimum of six at a time. I'm sure this didn't go over well with the distributors or many of the retailers. I remember contemplating whether or not I wanted to continue selling the pump. I'd have to plan ahead what I wanted to stock, lay out more money at one time, wait for the time I mailed the check for the pumps to arrive, then wait for the pumps to ship, and finally, for the pumps to arrive at my store. I decided that I wanted to continue selling the pump as there was nothing on the market like it.

I sent off my first check for an order of six pumps, the minimum a dealer could purchase. It probably took two weeks for the pump to arrive via the USPS. When I sold four pumps, I ordered another six. I repeated this several times: mail the check and wait two weeks. My last order didn't arrive after two weeks, so I waited and waited. Finally, I wrote to the company but never got a reply. After another several weeks, I wrote again and didn't get a reply. The check was cashed, but the pumps never arrived. I was not a happy camper and vowed to never deal with the company again, even if the company still existed. I think this was the end.

This unfortunate occurrence most likely happened in the late 1980s. I never followed up to check what really happened to the company as I was not going to talk about or further promote anything to do with Silent Giants.

Now that there were no Silent Giant pumps to sell or repair kits available, there was still a demand for repair parts. I had heard that there was a company making repair kits (Figs. 18 and 19). I contacted them and bought some kits to sell and use. After a few years, I tried to buy some more kits and they were no longer available.

So ended the era of the Silent Giant air pump, lasting about 30 years. As far as I know, there was never another pump using the oscillatory compressor design. The era of pumps made in the United States apparently also ended.



Figure 18 Fountain's aquarium repair kit and letter - mid 1980s

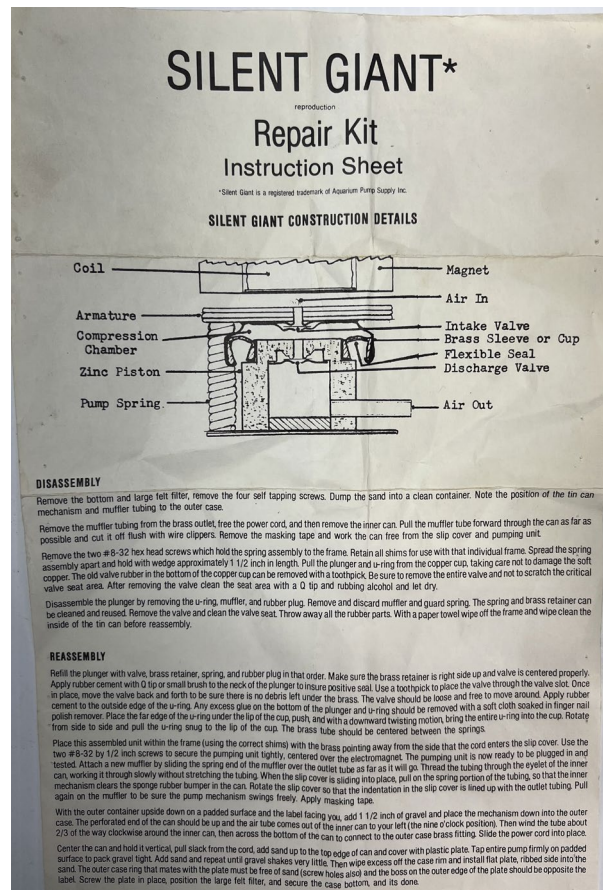

Figure 19 Fountain's aquarium repair kit instruction sheet

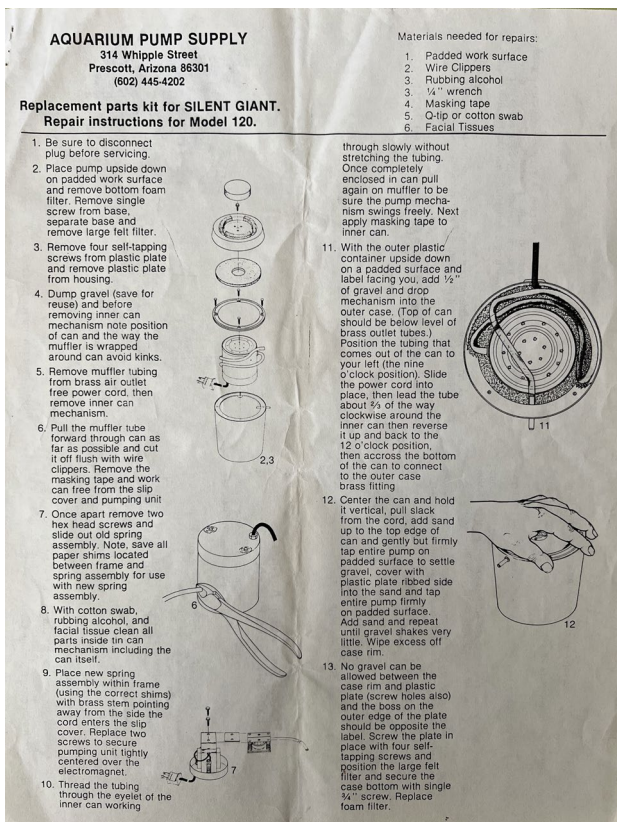

Figure 20A Silent Giant repair kit instructions - front page

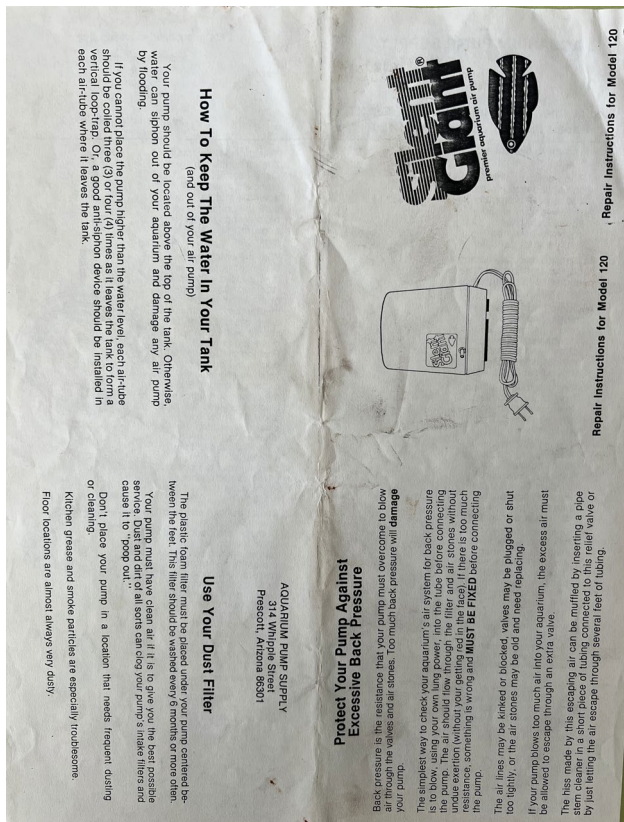

Figure 20B Silent Giant repair kit instructions - back page



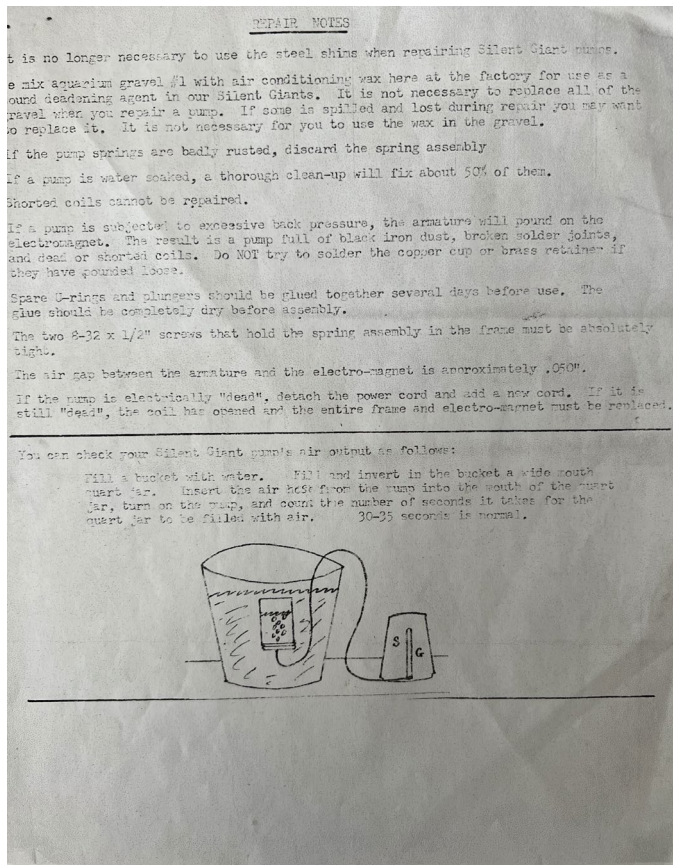

Figure 21 Dealer Repair Notes

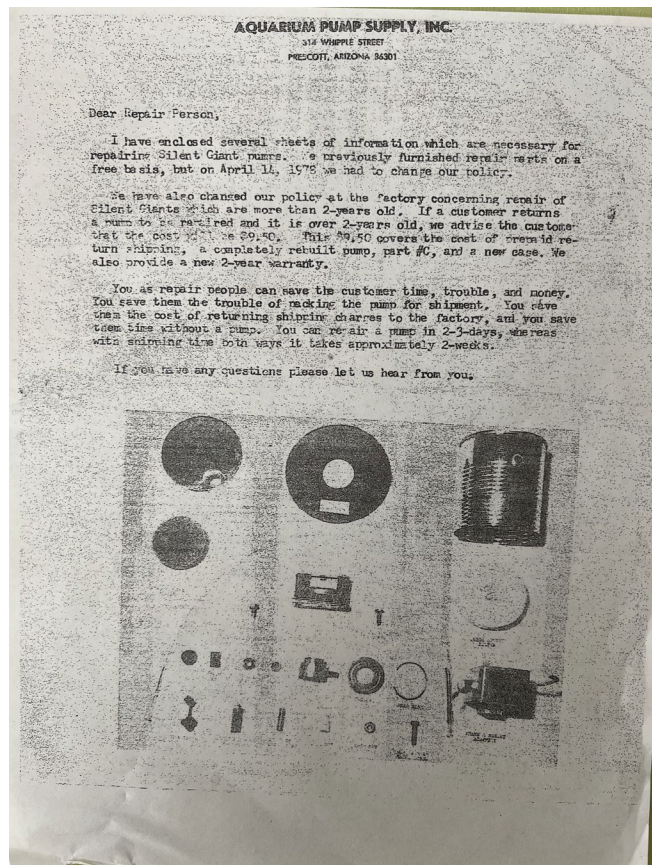

Figure 22 Letter to repair persons and parts photo

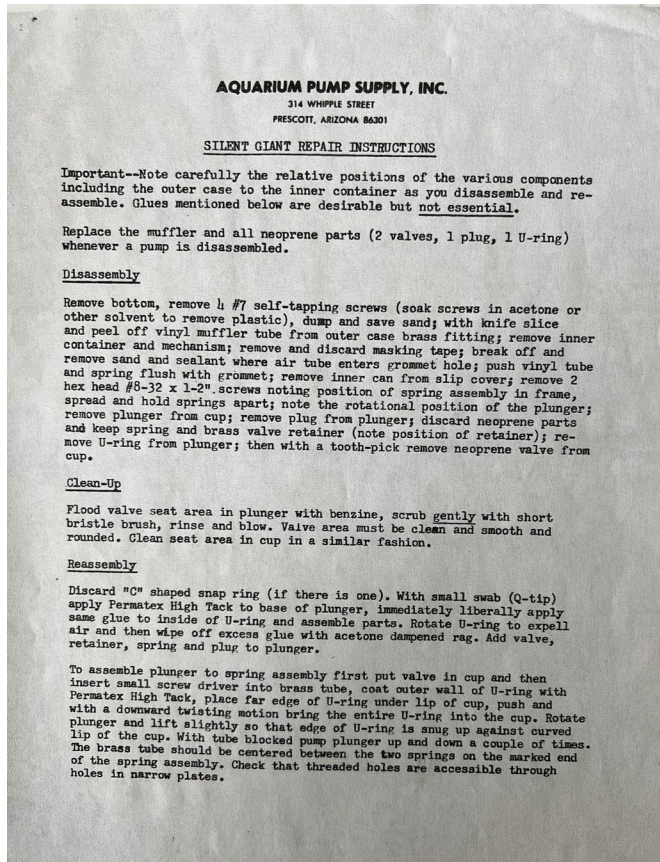

Figure 23A Dealer repair instructions - front page

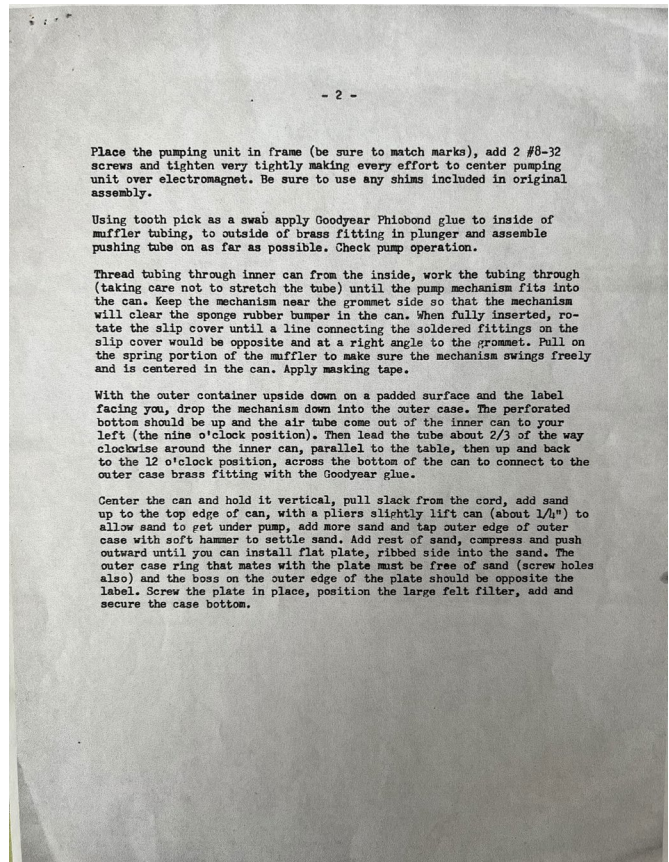

Figure 23B Dealer repair instructions - back page

## MY REPAIR HISTORY

I certainly didn't intend to repair Silent Giants when I started in business in the early 1960s, much less any other aquarium-related items. I always liked tinkering and repairing things, so I naturally started to repair aquariums and equipment that customers brought in.

After selling the Silent Giant pumps for a few years, some people had their pumps fail, mainly because they misused the pump by having too much back pressure. The pump could be sent back for a free repair or for a charge after the warranty ended. But then the aquarists would be without a pump. Customers were not happy. This bothered me as I couldn't repair the pump without parts. I wrote to the company and inquired if I could repair the pumps. I'm sure some other retailers did the same. The company replied and sent me parts free and instructions on how to repair the pumps. Hence, I became an authorized dealer. This was in the early 1960s when the company still had the two-year warranty. The company would send me whatever part I requested. I think I charged the customer \$5.00 for the repair, and would have it done the same day or the next day.

Even though I followed the instructions, it was still a "learn as you go" process. Some repairs went well, but others gave me trouble. I slowly learned through trial and error. I felt there had to be a better way to make sure the pump was pumping at full potential.

I thought that I should be able to measure the air output as well as the pressure. The company suggested that a pump could be checked for air output by filling a bucket with water, then submerging a quart jar so that it is upside down and filled with water. The output hose is then placed in the quart jar. You record how much time it takes to fill the jar with air (Fig. 21). This seemed like a lot of trouble.

I mentioned this to Carl Naja, and he gave me a small glass flow gauge. But it was designed to use mercury, and it didn't register the air output that aquarium pumps put out. I tried water in it, but it blew the water out. So I figured if I cut the glass tubes and made it longer and used water, it would resist the air output. It worked! So that's what I still use today to test the volume, along with a pressure gauge.

As time went on, I continued to repair the pumps for customers who didn't want to send their pumps in and also for those whose pumps were out of warranty. In the early years, I'd give the customer a loaner pump and charge \$5.00. There were also customers who would just buy a new Silent Giant and leave the old one. I'd throw the used one under my workbench. These were the ones that I would sell years later.

Sometime in the 1970s, I received a letter (Fig. 22) stating that they were changing the policy of free parts and would now be charging for them. Of course, I had to raise my prices.

That might have been about the same time that the company offered repair kits (Fig. 19) to retailers to sell to customers who wanted to repair their own pumps. I stocked these for those customers who wanted to repair the pumps themselves. I think they retailed for under five dollars. Some customers succeed with the repairs. However, there were many who couldn't get their pumps to pump. Thus, they'd bring the pump back to me for repair. After a while, I told the customer when they bought the kit, that if they couldn't get the pump repaired, just bring it back disassembled and I'd repair it for my normal price of \$10.00 less the cost of the repair kit. Many customers took advantage of that.

# AQUARIUM PUMP SUPPLY

314 WHIPPLE STREET  
PRESCOTT, ARIZONA 86301

*Fish Paradise*

PART NO.	NUMBER REQUIRED	PART NAME	DEALER COST
1	1	Muffler	.15
2	1	Rubber Plug	.05
3	2	Valves	.05/2 pieces
4	1	U-Ring	.10
24 - A		Repair Set - Parts Nos. 1-4	.25
5	1	Zinc Plunger	.30
6	1	Brass Valve Retainer	.05
7	1	Retainer Spring	.05
8	1	Spring Assembly	1.25
B		Replacement Pump Unit Parts 1-8, Assembled	1.75
9	1	Frame and Magnet Assembly	2.00
10	2	Support Spring Assembly	.10 each
11	1	Slip Cover	.05
12	1	#2P-1 Heyco	.05
13	2	Wire Nuts	.05 each
14	1	Inner Can with Filter	.30
15	1	Power Supply Cord	.40
16	1	Plastic Case-Top Assembly	.80
17	1	Plastic Case-Base with Feet	.70
18	1	Plastic Case-Circular Plate	.15
19	1	Plastic Case-White Diverter Disc	.05
20	3	Plastic Case-Sponge Rubber Feet	.10/3 pieces
21	1	Plastic Case-Large Felt Filter	.10
22	1	Intake Air Filter-Foam	.05
23	2	8 - 32 x 1/2" Machine Screws	.05 each
24	1	8 - 32 x 3/4" Machine Screws	.05 each
25	4	#7 FZ Self-Tapping Screw	.05 each
26	1	8 - 32 Hex Nuts	.05 each
C		Assembly - Parts B & 9, Assembled & Adjusted	4.50
AR		U-ring adhesive, 1-vial	.50

*Packing Slip  
9-26-79*

MINIMUM ORDER - \$2.50

(Please include check to cover the amount of order)

UPS COD #7.00

PRICES SUBJECT TO CHANGE WITHOUT NOTICE

4-15-78

Figure 24 List of parts and cost - 4/15/1978.

In the 1980s, the sales of all air pumps were slowing due to the sales of power heads and power filters. My repair service of the Silent Giants was also declining. When the company started selling the pumps directly to the retailers, and I never received my final shipment of pumps, that was the end of my sales of Silent Giants. Little by little, customers didn't bring in pumps for me to repair. There were other pumps available, so the Silent Giant was just about forgotten.

About 20 years passed, and one day a customer came in who had 4 Silent Giants but only wanted one repaired, and let me have the other three. That got me thinking that I should repair those old pumps under my workbench and sell them. People seemed to like the Silent Giants whenever they were mentioned.

I still had a lot of extra parts, so why not try to repair them and sell them then? I sold some repaired pumps in my shop, but thought eBay might give me better exposure.

Luckily, I had lots of extra parts, but I was running low on some that I could reproduce. I was running low on the flappers. Years ago, I acquired some thin reinforced sheet rubber that I could use for the flappers, which was probably better than the original material. I made a die punch to make them the same diameter as the originals. I made a jig to cut out the foam for the prefilter that fits under the pump to catch dust. I learned how to repair cracked cases and fill in missing areas with pieces from old cases by solvent bonding them together. I also acquired some black foam rubber to make replacement feet. All I had to do was cut them to the same size and glue them in.

#### **TECHNICAL STUFF**

There isn't much that could be changed when repairing a Silent Giant. The few things that could be changed were making sure the flappers were seated correctly and the "U" ring was glued in correctly. Also, the distance between the electromagnet and the piston assembly was the correct distance by trying different thicknesses of the shims.

Early in my repairing days, I noticed many pumps that came in for repair smelled like smoke from cigarettes, as many people smoked in their houses in the 1960s. I also noticed that the string muffler in the output tube was black and sticky from the smoke. I could hardly blow through those muffler tubes! The string muffler (Figs. 27 and 28) was collecting the smoke and stopping the air from leaving the pump, causing back pressure and thus the banging of parts, creating metal dust, and further causing the pump to fail. I thought, "Why even have that string in there"? The only purpose I could see was that it made the pump quieter, especially when it wasn't connected to anything, as when showing it to a customer, how quiet it was compared to other pumps. Later, I tested my theory on my flow gauge, and it also showed that without the string muffler, the pump could produce more air (Figs. 25 and 26). Thus, I always felt like that string was a gimmick and didn't do much when the pump was put into service.

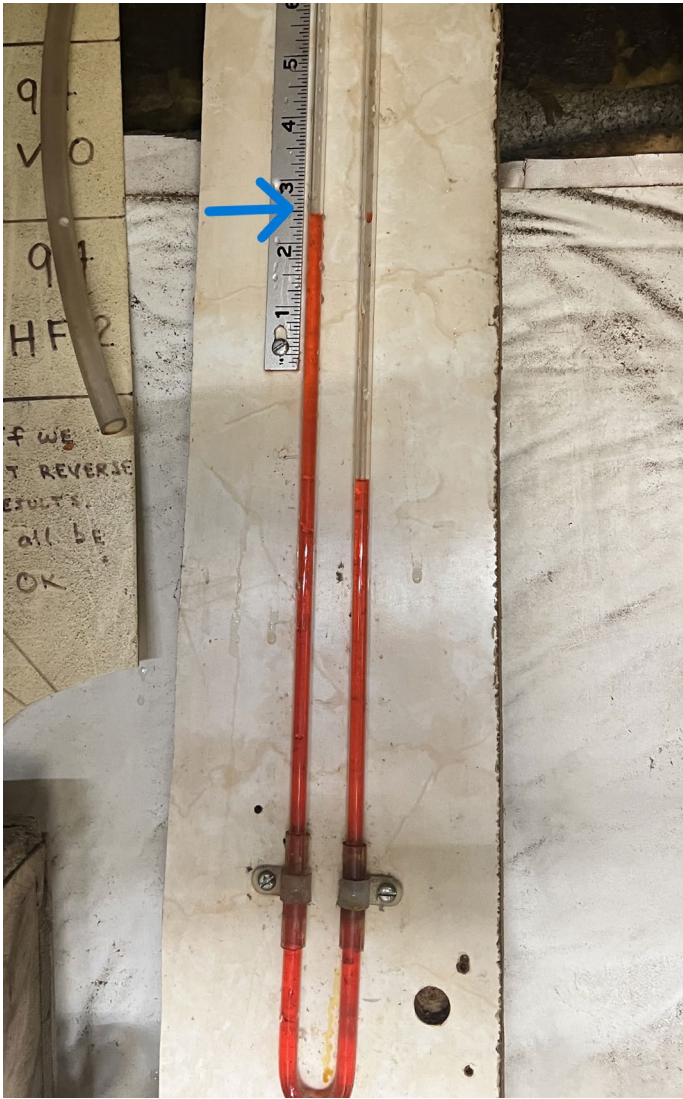

Figure 25 Lower volume with muffler string



Figure 26 Higher volume without string

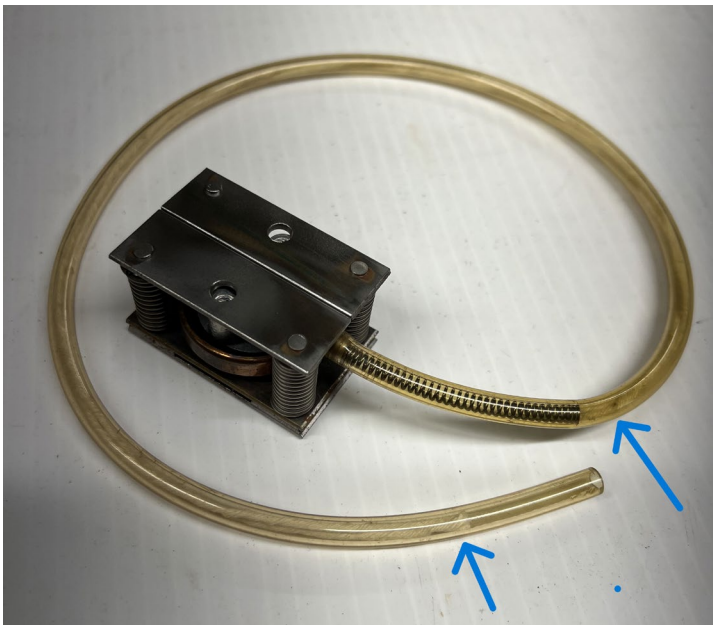

Figure 27 New muffer hose with string



Figure 28 Clogged muffer hose

I was asked many times: if the Silent Giant is such a good pump, why would it fail?

The simple answer is: misuse. Actually, that is true of all air pumps, especially those using the vibrator principle and rubber parts. What happens is that overheating degrades the rubber. The instructions that come with Silent Giant pumps mention this. I always told customers to make sure they use ALL the air the pump can produce. The easy test for that is if you can blow through the air hose without “getting red in the face”. A simple test. But aquarists would not try that test as all their air-operated devices were working. Little did they know that heat would build up and slowly harden the rubber parts. At the same time, the electromagnet would make contact with the piston mechanism and bang together, making fine metal dust. This metal dust would get caught in the string muffler and make more back pressure, much like the cigarette smoke would do. It should be mentioned that the “banging” was not usually noticed because of how quiet the Silent Giant is, and also, the pump was usually placed out of view. In vibrator pumps, the “banging” wouldn’t occur, but the heat would cause the rubber parts to fail.

## CONCLUSION

My involvement with the Silent Giant was not planned – it just happened. Just like many things in life, a lot is by chance. You go with it at the time, and sometimes the time runs on for quite a while. Then, as time passes and you look back, you can’t believe what has transpired, hopefully, for the best.

Things come and go. Some things come back, like vinyl records, and others fade away, like 8-track tapes. The Silent Giant is still admired and used by some, but as time passes, it might just fade away.

If anyone has more on the history or wishes to correct what I have written, I welcome all comments and thoughts.



Silent Giant Master Box



Silent Giant Box

**INVOICE**

INVOICE NO.

D-830519-01

AQUARIUM PUMP SUPPLY  
314 WHIPPLE STREET  
PRESCOTT, AZ. 86301  
(602) 445-4202

**S  
O  
L  
D  
T  
O** . NAJA AQUARIUM SUPPLY  
3001 S. 11th ST.  
MILWAUKEE, WI 54301

**S  
H  
I  
P  
T  
O**

SHIPPED VIA

CUSTOMER'S ORDER		OUR ORDER NUMBER	SALESMAN	TERMS	DATE SHIPPED	F.O.B.	DATE
		5371	Marla	CIA	5-19-83	Yellow	5-19-83
QUANTITY ORDERED	QUANTITY SHIPPED	DESCRIPTION				UNIT PRICE	AMOUNT
66	66	Silent Giant #120 Air Pump				12 35	815 10
54	54	Silent Giant Repair Kit				4 04	218 16
12	12	Foam Filter Cards				2 19	26 28
TOTAL							1,059.54
CM #9541							(205.20)
BALANCE							854 34
BLANCE PAID 4-4-83 CHECK #1383							
THANK YOU!							

RECIFORM 75733  
POLY PAK (50 SETS) 7P733

Invoice from MOAPH collection from Aquarium Pump Supply that includes Silent Giant Air Pumps and a Silent Giant repair kits. The date on the invoice is listed as 5/19/83.



Two "knock-off" air pumps made to look like the Silent Giant. These were made after the Silent Giant's patent had expired, although the inside mechanism was a simple vibrator type air pump.